

FICHE D'HOMOLOGATION HOMOLOGATION FORM



COMMISSION INTERNATIONALE DE KARTING - FIA



MOTEUR / ENGINE KZ1 / KZ2

Constructeur	<i>Manufacturer</i>	C.R.S SRL
Marque	<i>Make</i>	CRS
Modèle	<i>Model</i>	G1
Type d'admission	<i>Inlet type</i>	REED VALVE
Durée de l'homologation	<i>Validity of the homologation</i>	9 ans / 9 years
Nombre de pages	<i>Number of pages</i>	10

La présente Fiche d'Homologation reproduit descriptions, illustrations et dimensions du moteur au moment de l'homologation CIK-FIA. Le Constructeur a la possibilité de les modifier seulement dans les limites fixées par le Règlement CIK-FIA en vigueur. La hauteur du moteur complet sur les photos doit être de 7cm minimum.

This Homologation Form reproduces descriptions, illustrations and dimensions of the engine at the moment of the CIK-FIA homologation. The Manufacturer may modify them, but only within the limits fixed by the CIK-FIA Regulations in force. The height of complete engines on all photos must be minimum 7cm.



PHOTO DU MOTEUR CÔTÉ PIGNON
PHOTO OF DRIVE SIDE OF ENGINE



PHOTO DU MOTEUR CÔTÉ OPPOSÉ
PHOTO OF OPPOSITE SIDE OF ENGINE

Signature et tampon de l'ASN
Signature and stamp of the ASN

Signature et tampon de la CIK-FIA
Signature and stamp of the CIK-FIA



Grasso



[Signature]

INFORMATIONS TECHNIQUES		TECHNICAL INFORMATION	
A	CARACTÉRISTIQUES	A	CHARACTERISTICS
			Tolérances
Volume du cylindre	<i>Volume of cylinder</i>	124,66 CM3	< 125cm ³
Alésage d'origine	<i>Original Bore</i>	53,98 MM	
Alésage théorique maximum	<i>Theoretical maximum bore</i>	54,05 MM	
Course	<i>Stroke</i>	54,50 MM	
Système de refroidissement	<i>Cooling system</i>	WATER -COOLED	
Nombre de systèmes de carburation	<i>Number of carburation systems</i>	1	
Nombre de canaux de transfert, cylindre/carter	<i>Number of transfer ducts, cylinder/sump</i>	5 / 3	
Nombre de lumières / canaux d'échappement	<i>Number of exhaust ports / ducts</i>	3	
Forme de la chambre de combustion	<i>Shape of the combustion chamber</i>	SPHERICAL WITH SQUISH	
Matériau de la paroi du cylindre	<i>Cylinder wall material</i>	NIKASIL OR IRON	
Longueur (entre-axe) de la bielle	<i>Length between the axes of the connecting rod</i>	108	±0.1mm
Volume de la chambre de combustion	<i>Volume of combustion chamber</i>	11 C.C.	Minimum
Nombre de segments de piston	<i>Number of piston rings</i>	1	
Modifications autorisées selon le Règlement Technique. Seules les dimensions et cotes qui ne peuvent pas être modifiées doivent figurer sur la Fiche d'Homologation.			
<i>Modification allowed according to the Technical Regulations. Only the dimensions and readings which may not be changed must be mentioned on the Homologation Form.</i>			

B	ANGLES D'OUVERTURE	B	OPENING ANGLES
De l'échappement	<i>Exhaust</i>	199°	Max

C	MATÉRIAU	C	MATERIAL
Cylindre	<i>Cylinder</i>		AL-SI ALLOY
Culasse	<i>Cylinder head</i>		AL-SI ALLOY OR BRONZE OR IRON
Carter	<i>Sump</i>		AL-SI ALLOY
Bielle	<i>Connecting rod</i>		CR-MO STEEL

DESSIN DU DÉVELOPPEMENT DU CYLINDRE

DRAWING OF THE CYLINDER DEVELOPMENT

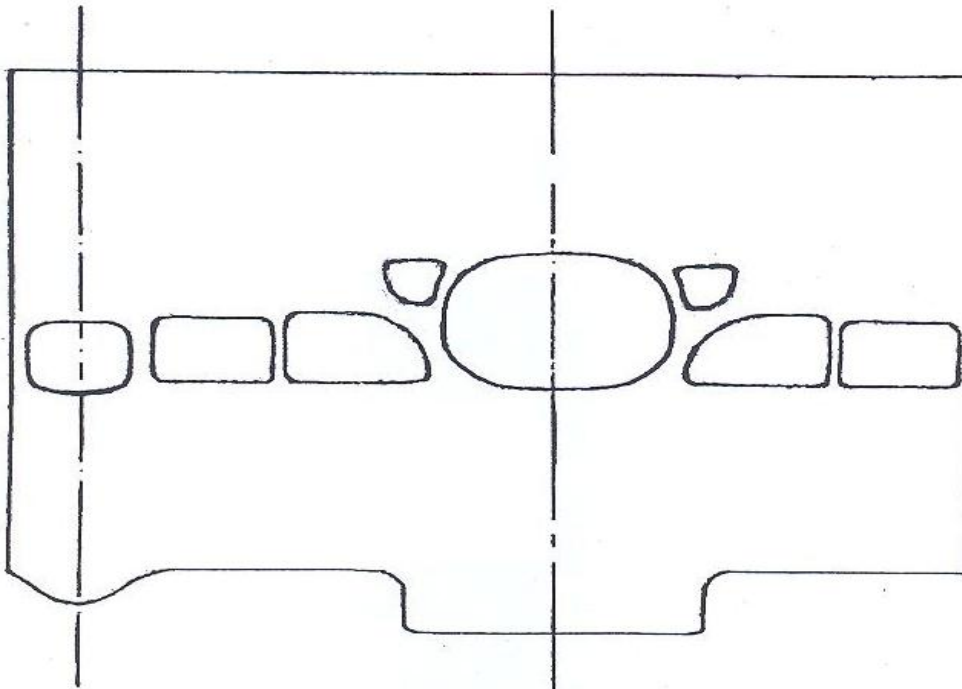
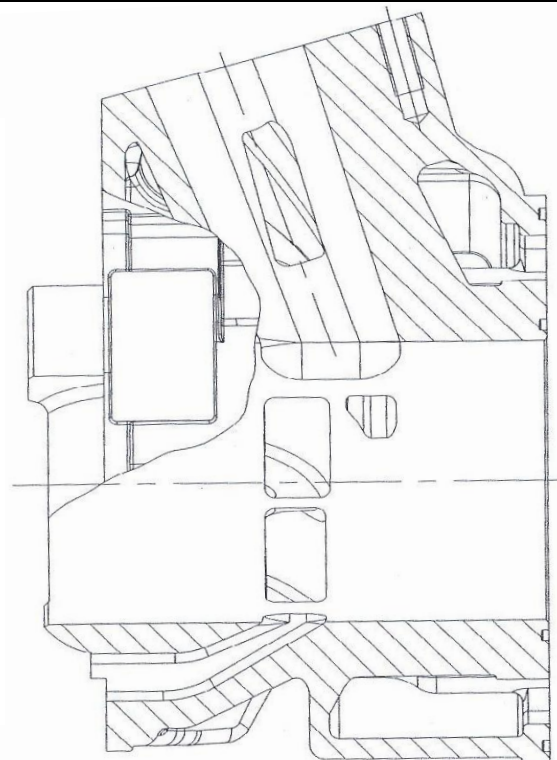
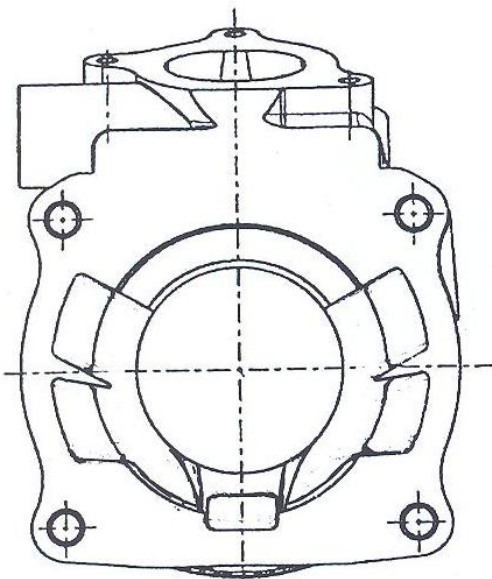
DESSIN DU PIED DU
CYLINDREDRAWING OF THE
CYLINDER BASEVUE EN SECTION DU
CYLINDRESECTION VIEW OF
CYLINDER

DESSIN DE LA CULASSE ET DE LA CHAMBRE
DE COMBUSTION

*DRAWING OF THE CYLINDER HEAD AND OF
THE COMBUSTION CHAMBER*

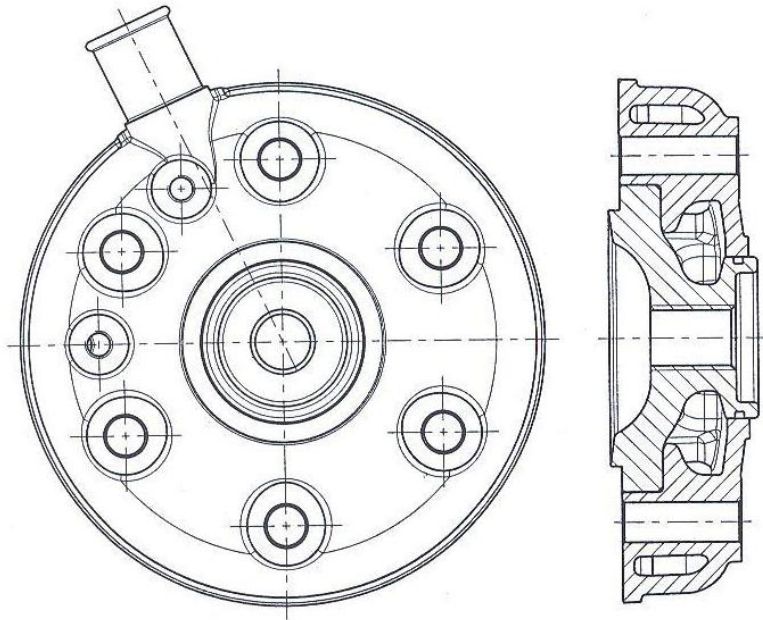

DESSIN DU
VILEBREQUIN

*DRAWING OF THE
CRANKSHAFT*

DESSIN INTÉRIEUR
DU CARTER

*DRAWING OF THE
INSIDE OF SUMP*

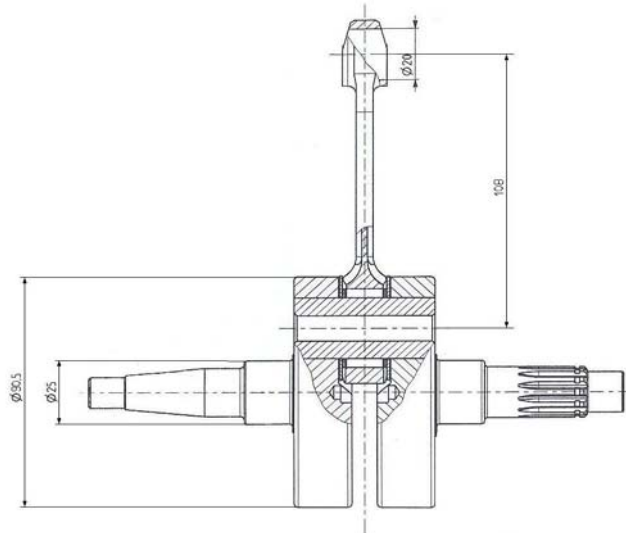

BORE:

Foot connecting- rod $\varnothing 20$.
Head connecting- rod $\varnothing 26$ or $\varnothing 31$.

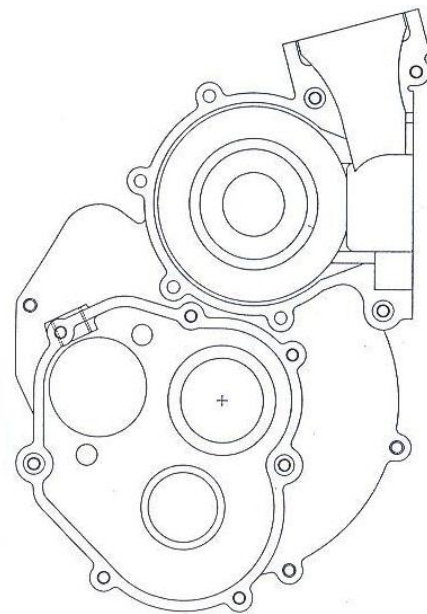



PHOTO DE L'ARRIÈRE DU MOTEUR	<i>PHOTO OF THE BACK OF THE ENGINE</i>	PHOTO DE L'AVANT DU MOTEUR	<i>PHOTO OF THE FRONT OF ENGINE</i>
			
PHOTO DU MOTEUR PARTIE SUPÉRIEURE	<i>PHOTO OF THE ENGINE TAKEN FROM ABOVE</i>	PHOTO DU MOTEUR PARTIE INFÉRIEURE	<i>PHOTO OF THE ENGINE TAKEN FROM BELOW</i>
			

PHOTO DU PIED DU CYLINDRE	<i>PHOTO OF THE BASE OF THE CYLINDER</i>	PHOTO DE LA CHAMBRE DE COMBUSTION	<i>PHOTO OF COMBUSTION CHAMBER</i>
			
PHOTO DU CARTER (CÔTÉ JOINT)	<i>PHOTO OF THE SUMP (GASKET FACE)</i>	PHOTO D'UNE PARTIE INTÉRIEURE DU CARTER	<i>PHOTO OF AN INTERNAL PART OF THE SUMP</i>
			

DESSIN DE LA BOÎTE À CLAPETS

DRAWING OF REED VALVE

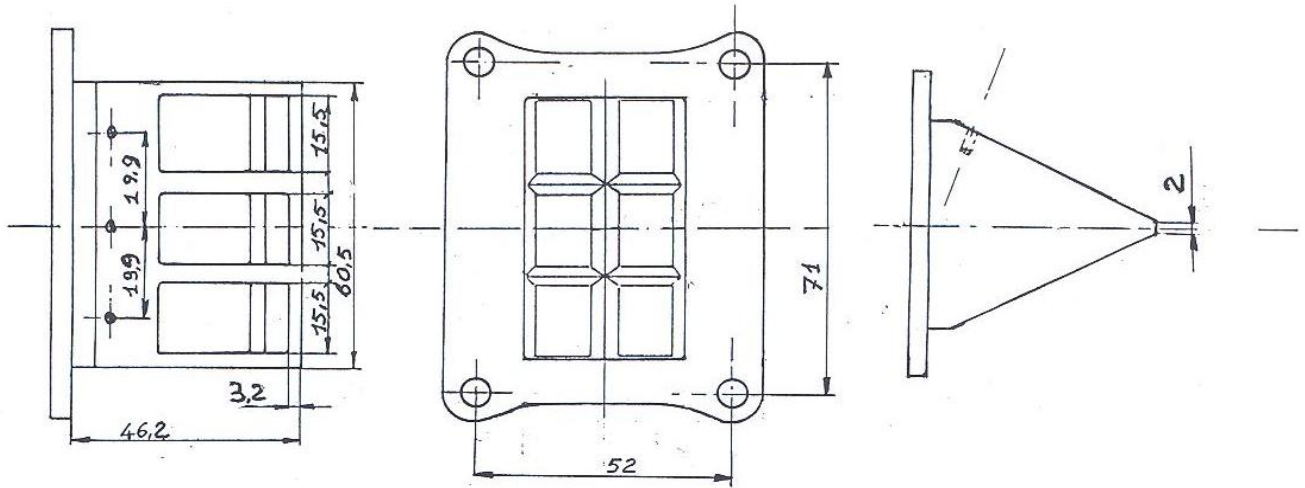

DESSIN DU COUVERCLE DE LA BOÎTE À CLAPETS

DRAWING OF REED VALVE COVER

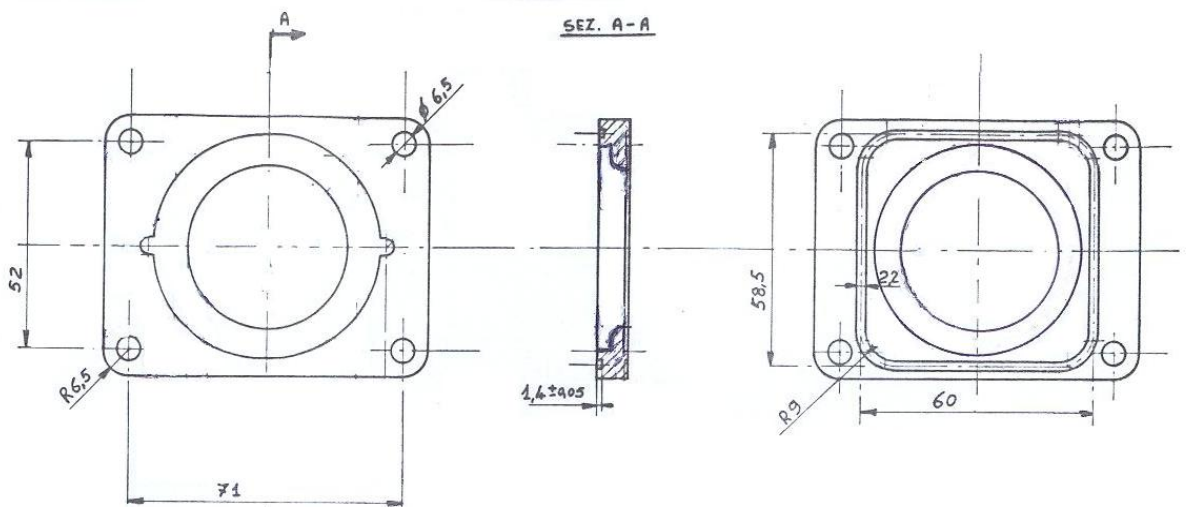

BOÎTE DE VITESSES		GEARBOX	
Couple primaire		<i>Primary coupling</i>	19/75
Rapports de boîte de vitesses		<i>Gearbox ratios</i>	
Vitesse	Arbre primaire	Arbre secondaire	Relevé des valeurs obtenues après trois tours moteur
<i>Gear</i>	<i>Primary shaft</i>	<i>Secondary shaft</i>	<i>Reading of values obtained after three engine revs</i>
1 ^{ère} /1 st	13	34	104,5°
2 ^e /2 nd	16	29	150,8°
3 ^e /3 rd	18	27	182,2°
4 ^e /4 th	22	27	222,7°
5 ^e /5 th	22	23	261,6°
6 ^e /6 th	26	24	296,3°

PHOTOS DE L'ÉCHAPPEMENT	PHOTOS OF THE EXHAUST
	

DESCRIPTIONS TECHNIQUES		TECHNICAL DESCRIPTIONS	
Poids en gr	<i>Weight in gr</i>	1040	<i>Minimum</i>
Volume in cm ³	<i>Volume in cc</i>	3590	<i>+/-5 %</i>

DESSINS TECHNIQUES	TECHNICAL DRAWINGS
Contenant toutes les informations permettant de construire cet échappement.	<i>Including all the information necessary to build this exhaust.</i>

We reserve us the right to straighten the exhaust (if it is crushed) before the control.

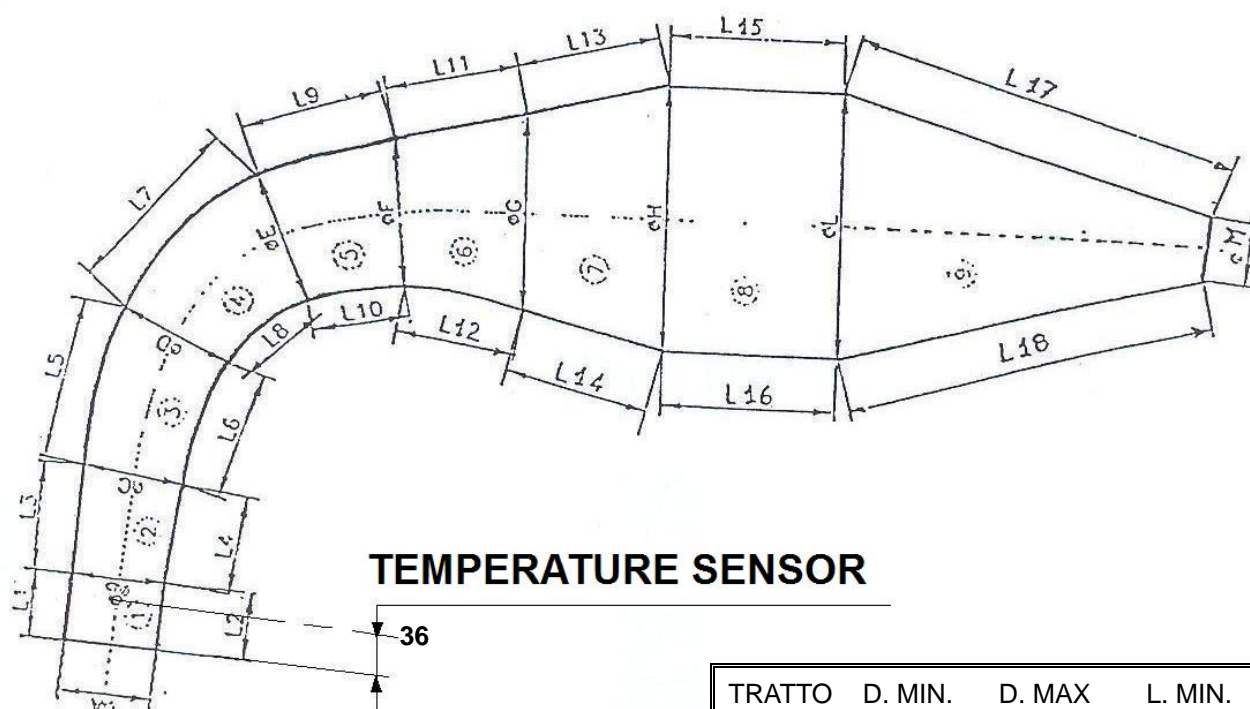

TEMPERATURE SENSOR

External measures

TRATTO	D. MIN.	D. MAX	L. MIN.	L. MAX
1	Ø A 41.6	Ø B 44.8	L2 51	L1 57.8
2	Ø B 44.8	Ø C 47.7	L4 42	L3 50
3	Ø C 47.7	Ø D 51.5	L6 40	L5 51.5
4	Ø D 51.5	Ø E 64	L8 46.5	L7 61
5	Ø E 64	Ø F 79	L10 45.5	L9 65.5
6	Ø F 79	Ø G 92	L12 37	L11 54
7	Ø G 92	Ø H 127	L14 92.5	L13 117
8	Ø H 127	Ø L 127	L16 70	L15 70
9	Ø L 127	Ø M 26.6	L18 185	L17 208

POSITION DES CODE-BARRES BAR CODE LOCATION



COMMISSION INTERNATIONALE DE KARTING - FIA



MOTEUR / ENGINE KF – KZ

Constructeur	<i>Manufacturer</i>	C.R.S. SRL
Marque	<i>Make</i>	CRS
Modèle	<i>Model</i>	G1

Marquage des moteurs aux Vérifications Techniques :

Deux étiquettes autocollantes par moteur, l'une pour le cylindre et l'autre pour un demi-carter, seront fournies et mises en place par les Commissaires Techniques sous le contrôle de la CIK-FIA. Les moteurs, qui seront marqués de deux autocollants devront comporter des emplacements de 28 x 20 mm, totalement propres et dégraissés, et fraisés selon les positions décrites sur une annexe à la Fiche d'Homologation.

A tout moment de l'Epreuve, les marquages devront être intacts et parfaitement lisibles. Il est interdit d'appliquer un matériau ou un produit quelconque sur les marquages. Un marquage détérioré ou illisible, qu'elle qu'en soit la raison, sera passible pour le Pilote concerné de l'exclusion de l'Epreuve. La même sanction sera applicable en cas d'échange de matériel entre Pilotes. Les Concurrents concernés et tous les Pilotes qu'ils auront inscrits pourront être exclus du Championnat dans lequel une irrégularité concernant le marquage aura été constatée.

Avant et après chaque séance d'Essais, chaque Manche et chaque Course de la phase finale, les Commissaires Techniques pourront vérifier si le marquage du matériel est conforme. A la fin de chaque séance d'Essais, chaque Manche et chaque Course de la phase finale, le Pilote devra s'assurer que les marquages sont intacts. Si un marquage subit une altération ou une déformation, le Pilote devra en informer immédiatement le Délégué Technique ou le Commissaire Technique en Chef avant de quitter le Parc d'Assistance.

Marking of the engines at Scrutineering:

Two stickers per engine, one for the cylinder and the other for one of the half sumps, will be supplied and attached by the Scrutineers under the control of the CIK-FIA.

The engines, which will be marked with two stickers shall comprise spaces of 28 mm x 20 mm totally clean and without any grease, milled in accordance with the locations described on an appendix to the Homologation Form.

At all times throughout the Event these official markings shall be intact and perfectly readable. It is forbidden to apply any material or product on the markings. A Driver with a marking that is damaged or unreadable for whatever reason will be liable to exclusion from the Event. The same sanction will be applicable in the event of an exchange of equipment between Drivers. The Entrants concerned and all the Drivers they have entered may be excluded from the Championship in which an irregularity concerning the marking has been ascertained.

Before and after every Practice session, every Heat and every Race of the final phase, the Scrutineers may control whether the marking of the equipment complies with the rule. At the end of every Practice session, every Heat and every Race of the final phase the Driver shall ensure that his markings are intact. If a marking has undergone an alteration or a deformation, the Driver shall immediately inform the Technical Delegate or the Chief Scrutineer before leaving the Servicing Park.



POSITIONNEMENT CARTER
LOCATION ON THE ENGINE SUMP



POSITIONNEMENT CYLINDRE
LOCATION ON THE CYLINDER